

The new BMW M6 Coupe. The new BMW M6 Convertible. Contents.



1. At a glance.	2
2. Aesthetic allure meets high performance: The new BMW M6 Coupe. The new BMW M6 Convertible.	6
3. Specifications.	18
4. Output and torque diagrams.	22
5. Exterior and interior dimensions.	23

1. At a glance.



- New edition of the BMW M6 in Coupe and Convertible body variants; generous dose of M feeling combined with alluring design aesthetics, a luxurious aura, seating for four and innovative equipment features; high-performance sports car with superior performance attributes and extremely exclusive character; BMW M6 Coupe and BMW M6 Convertible both occupy a unique position in the premium segment of the executive class thanks to their blend of outstanding dynamics, hallmark M conceptual harmony and everyday usability; further development of both concepts breaks new ground with significantly improved efficiency, optimised controls for individualising the car set-up and a wider variety of driver assistance systems and infotainment functions available from BMW ConnectedDrive.
- Visually imposing body design with dynamically elegant lines and hallmark M athleticism provides an accurate visual showcase for the car's high-performance properties; BMW M6 Coupe with strikingly contoured roof made from carbon fibre-reinforced plastic (CFRP); BMW M6 Convertible with high-quality soft-top boasting distinctive "fin" architecture.
- High-revving 4.4-litre V8 engine with M TwinPower Turbo technology, consisting of Twin Scroll Twin Turbo technology, cross-bank exhaust manifold, High Precision Direct Petrol Injection and VALVETRONIC fully variable valve control; hallmark M power delivery headlined by instantaneous responsiveness and a sustained wave of thrust; highest output in the segment; 412 kW/560 hp at 6,000 – 7,000 rpm, maximum torque: 680 Newton metres (502 lb-ft) from 1,500 rpm; maximum engine speed: 7,200 rpm; engine output 10 per cent higher than predecessor models, maximum torque 30 per cent higher.
- Acceleration: 0–100 km/h (62 mph) in 4.2 seconds (BMW M6 Coupe) or 4.3 seconds (BMW M6 Convertible); 0–200 km/h (124 mph) in 12.6 (13.1) seconds; electronically governed top speed: 250 km/h (155 mph) or 305 km/h (189 mph) with M Driver's Package.

- Extraordinarily fine balance between performance and fuel consumption represents major improvement on previous models; average fuel consumption in the EU test cycle: 9.9 litres per 100 km / 28.5 mpg imp (BMW M6 Coupe) and 10.3 litres per 100 km / 27.4 mpg imp (BMW M6 Convertible); Auto Start-Stop function and further Efficient Dynamics technology as standard; fuel consumption of the respective predecessor models cut by more than 30 per cent.
- Seven-speed M Double Clutch Transmission with Drivelogic; automatic gear selection tuned to deliver optimum traction, Launch Control and Low Speed Assistance; bespoke M gear selector; newly developed M leather steering wheel with gearshift paddles.
- Power sent to the rear wheels; Active M Differential ensures fully variable distribution of drive between the rear wheels. Result is optimised traction and directional stability during dynamic lane changes and when accelerating out of corners.
- High-performance characteristics with outstanding dynamics and precisely controllable handling, thanks to hallmark M harmony in the interplay of powertrain and chassis technology, aerodynamics and weight balance; weight-to-power ratio – BMW M6 Coupe: 3.3 kg/hp (7.3 lb/hp), BMW M6 Convertible: 3.5 kg/hp (7.7 lb/hp).
- M-specific chassis with bespoke front and rear axle kinematics; M-specific Dynamic Damper Control as standard; DSC stability control incl. M Dynamic Mode; M Servotronic steering; body strengthening using special panels; lightweight compound high-performance braking system; available as an option are newly developed, globally unique M carbon-ceramic brakes with optimum resistance to fade and wear, and lower weight.
- Engine responses, M Servotronic mapping, Drivelogic shift program, DSC mode, damper characteristics and information shown on the Head-Up Display can be programmed individually; two M Drive buttons on the steering wheel can be used to store and call up individually configured car set-up options.

- Body design with classical BMW Coupe/Convertible proportions, customary sporty yet elegant BMW 6 Series looks and typical M sporting edge; special M design features provide an accurate visual representation of the car's technical profile and performance; three-section, strikingly modelled lower air intake with aerodynamically optimised flaps; new M kidney grille with black double slats; flared wheel arches; hallmark M gills with integrated direction indicator bars; aerodynamically optimised exterior mirrors and side skirts; BMW Individual High-gloss Shadow Line; exposed reflectors below the rear lights; aerodynamically optimised rear apron with diffuser between the right and left-hand pair of twin exhaust tailpipes; 19-inch (standard) or 20-inch (optional) forged M light-alloy wheels, each with a distinctive interpretation of the familiar M double-spoke design.
- Luxurious, elegantly sweeping interior design with special M controls and styling features; newly developed M double-spoke leather steering wheel; M gear selector and car set-up controls on the model-specific centre console; exclusive M sports seats with integrated belt system (optional: M multifunction seats); Merino leather upholstery with extended features; exclusive carbon-fibre interior trim strips; illuminated door sill finishers with model lettering; M-specific instrument cluster with black-panel technology; 2-zone automatic climate control with extended features, ambient lighting.
- Adaptive LED Headlights fitted as standard, extensive range of BMW ConnectedDrive features, some unmatched by any rival: BMW Head-Up Display with M-specific information, High Beam Assistant, BMW Night Vision with pedestrian recognition, Lane Change Warning, Lane Departure Warning, rear-view camera, Surround View, Speed Limit Info, internet access, extended integration of smartphones and music players, Real-Time Traffic Information and apps for receiving web radio and using Facebook and Twitter.
- Almost all BMW 6 Series equipment options available, including Comfort Access, active seats, heated steering wheel, doors with Soft Close Automatic function, Navigation system Professional, Bang & Olufsen High- End Surround Sound System.

- Performance, fuel consumption and emissions data:

BMW M6 Coupe:

Acceleration [0 – 100 km/h (62 mph)]: 4.2 seconds,
acceleration [0 – 200 km/h (124 mph)]: 12.6 seconds,
top speed: 250 km/h (155 mph), 305 km/h (189 mph) with
M Driver's Package,

average fuel consumption: 9.9 litres/100 kilometres (28.5 mpg imp),
CO₂ emissions: 232 g/km, exhaust standard: EU5.

BMW M6 Convertible:

Acceleration [0 – 100 km/h (62 mph)]: 4.3 seconds,
acceleration [0 – 200 km/h (mph)]: 13.1 seconds,
top speed: 250 km/h (155 mph), 305 km/h (189 mph) with M Driver's
Package),

average fuel consumption: 10.3 litres/100 kilometres (27.4 mpg imp),
CO₂ emissions: 239 g/km, exhaust standard: EU5.



2. Aesthetic allure meets high performance: The new BMW M6 Coupe. The new BMW M6 Convertible.

Out of a passion for elite performance and an appreciation of exclusive style comes the allure for which M Automobiles are renowned – and which can now be experienced in two new forms. The new BMW M6 Coupe and BMW M6 Convertible offer top-class performance attributes and an ambience defined by luxury and innovative comfort features. In so doing, the high-performance sports cars developed by BMW M GmbH exude a level of poise and assurance unmatched in the premium segment of the executive class – and reflected authentically in the expressive design of the two models. The precise interplay of their high-revving V8 engine with M TwinPower Turbo technology and 412 kW/560 hp, a seven-speed M Double Clutch Transmission with Drivelogic, Active M Differential, model-specific chassis technology, an ideal weight balance and optimised aerodynamic properties serves up a particularly full-blooded M experience.

The conceptual harmony characteristic of M Automobiles also incorporates the specific features of the two models' body structures. The new BMW M6 Coupe has a dynamically contoured, lightweight roof made from carbon fibre- reinforced plastic. The new BMW M6 Convertible, meanwhile, is fitted with a high-quality soft-top, complete with eye-catching "fin" styling and fully electronic opening mechanism. All of which allows the driver and passengers to enjoy the dynamic performance of a high-performance sports car in harmony with the natural forces of the sun and wind.

The motor sport technology in the new BMW M6 Coupe and BMW M6 Convertible paves the way for imposing performance on the race track, but also treats the driver to a captivating driving experience on everyday journeys from A to B. The BMW M6 Coupe sprints from 0 to 100 km/h (62 mph) in 4.2 seconds, the BMW M6 Convertible in 4.3 seconds. However, the dynamic character of both models is also defined by their mid-range agility, the precision of their turn-in and traction when accelerating out of corners, their precisely controllable handling under intense lateral forces and their stopping capability. The latest innovation designed to optimise the

handling of the new BMW M6 Coupe and BMW M6 Convertible in highly dynamic driving situations are the M carbon-ceramic brakes, offered as an option for the first time.

Another attribute unmatched by any rival is the leap forward in efficiency that comes with the new editions of the two high-performance sports cars. The new BMW M6 Coupe records average fuel consumption of 9.9 litres per 100 kilometres (28.5 mpg imp) and CO₂ emissions of 232 grams per kilometre in the EU test cycle. The equivalent values for the new BMW M6 Convertible are 10.3 l/100 km (27.4 mpg imp) and 239 g/km. Despite a 10 per cent increase in engine output and a 30 per cent jump in peak torque – to 680 Newton metres (502 lb-ft) – fuel consumption and CO₂ emissions have been reduced by over 30 per cent in both cases compared with their respective predecessors.

Design: athletic aura, powerfully taut surfaces, elegant lines.

Classical proportions, the sporty yet elegant lines of the BMW 6 Series and the familiar design language of BMW M Automobiles form the foundations for the eloquent body design of the BMW M6 Coupe and BMW M6 Convertible. Powerfully taut surfaces and precise contours underline the athletic aura of the two models. In addition, a model-specific interpretation of hallmark M styling cues includes design details which are influenced directly by technical considerations – such as the cooling air required, chassis geometry and aerodynamics – and therefore further highlight the cars' outstanding performance attributes. This is a fine example of how the ultra-dynamic character which marks out these most focused versions of the luxurious Coupe and exclusive Convertible is accurately expressed through their design.

Wide air intakes, stunningly contoured headlight units and large, smooth surfaces shape the front end of the new BMW M6 Coupe and BMW M6 Convertible. Another eye-catching element of the car's nose is its newly designed M kidney grille, which bears an "M6" badge. The grille's black, paired kidney grille slats take their cues from the characteristic double-spoke design of the M light-alloy wheels. The 30-millimetre increase in track width over the two cars' respective 6 Series stablemates is complemented by powerfully flared front wheel arches, which sit flush with the wheels. This extra width offers a clear nod to the optimised roadholding of these

high-performance sports cars. The three-dimensional shaping of their air intakes and race-inspired flaps designed to optimise airflow to the outer air intakes likewise underline the cars' forward-surgingly dynamic character.

An LED accent light cuts across the tops of the Adaptive LED Headlights fitted as standard on both models. Their bright white, three-dimensional LED light rings are levelled off to striking effect at the top and lower edges. Both dipped beam and main beam use both light rings. Providing the light are LED units, which are placed on a horizontal rib running through the centre of the units and feed their light into the reflectors in front of them. This ensures that the distinctive appearance of the twin circular headlights comes across clearly in every situation. The direction indicators – in the form of horizontally arranged LED units – are integrated into the headlight units below the light rings.

The familiar M athleticism of both models is also clearly visible from the side. The front side sections of the car feature familiar M gills. Their three-dimensional shaping, wide chrome frames and indicator bars – which bear the M logo – give them an extremely deep-set look. In tune with the wider wheel arches, the character lines around the gills are suitably prominent. Eye-catching creases on the likewise model-specific side skirts sweep upwards, diverting the gaze to the rear wheels. The new BMW M6 Coupe and BMW M6 Convertible are fitted with 19-inch M light-alloy wheels as standard. The forged wheels feature seven double-spokes in a two-tone finish. The optional 20-inch M light-alloy wheels, meanwhile, hint at reduced weight with their five intricate double-spokes and allow a clear line of sight through to the powerful braking system.

Broadening towards the road and incorporating horizontal lines and generous surfaces, the design of the rear end hints at the stable roadholding and powerful poise and assurance of the new BMW M6 Coupe and BMW M6 Convertible. The reflectors, positioned immediately below the L-shaped rear lights, provide an individual expression of sportiness. However, the clearest pointer to the unmistakable identity of the two high-performance sports cars are the familiar M twin exhaust tailpipes positioned to either side of the diffuser integrated into the rear apron. The form of the outer air intakes reflects the design of the front apron in their format and the contours of their surrounds.

Dynamic contours, lightweight material: the carbon fibre-reinforced plastic roof of the BMW M6 Coupe.

Like its predecessor, the roof of the new BMW M6 Coupe is made from carbon fibre-reinforced plastic as standard. The dark colouring of the roof gives the two-door car's silhouette an extremely elongated look, which is further emphasised by a dynamic recess in the centre of the roof. The use of the lightweight material for the roof allows the car's centre of gravity to be lowered, enhancing agility. BMW Individual High-gloss Shadow Line trim (standard) draws attention to this optimised weight balance, its dark colouring covering the side window borders (or the waistline in the case of the BMW M6 Convertible) and the base and lower section of the aerodynamically optimised M exterior mirror caps.

The exclusive looks of the new BMW 6 Series Convertible are underlined by the "fin" architecture of the high-quality soft-top roof. Projecting into the rear section, the fins accentuate the car's dynamically sweeping silhouette. The heated, vertical glass rear window, which is situated just behind the rear seats, retracts independently of the soft-top itself. The automatic opening and closing process for the roof can be activated both at a standstill and while on the move at speeds of up to 40 km/h (25 mph) using a button on the centre console. The optional Comfort Access allows the roof to be opened or closed by pressing the remote control button on the car key. It takes the roof 19 seconds to open and 24 seconds to close again.

Customers can choose from one non-metallic and eight metallic shades (including four exclusive M finishes) for the exterior paintwork of both models. The soft-top for the new BMW M6 Convertible is available in Black and Beige, or – as an option – in Anthracite Silver effect.

The engine: high-revving V8 with M TwinPower Turbo technology.

The new BMW M6 Coupe and Convertible showcase their individual style with a raft of unique styling touches and tweaks to the character of the driving experience. But they draw the output required to serve up their inspirational performance from the same source: a high-revving V8 engine with M TwinPower Turbo technology, longitudinally mounted at the front of the car, whose power is channelled to the rear wheels via a seven-speed M Double Clutch Transmission with Drivelogic. This powertrain combines

construction features taken directly from motor sport with innovations developed under the banner of Efficient Dynamics. Its globally unparalleled package of technology comprises two turbochargers working according to the twin-scroll principle (including a cross-bank exhaust manifold), High Precision Direct Petrol Injection, VALVETRONIC variable valve timing and Double-Vanos continuously variable camshaft control. The engine is also served by an extremely powerful cooling system and a wet sump oil supply optimised to work under high lateral forces.

The unmistakable, typically M performance characteristics of the 4.4-litre powerplant are defined by its lightning-quick responses and forceful, linear power delivery maintained into the higher reaches of the rev range. Indeed, peak torque of 680 Newton metres (502 lb-ft) is on tap between 1,500 and 5,750 rpm. The V8 achieves its maximum output of 412 kW/560 hp between 6,000 and 7,000 rpm and can spin on to 7,200 rpm. All of which means the rev band available in the new models to generate maximum performance is almost three times wider than that of the engine powering their predecessors.

This instantaneous and sustained power delivery is the key to unlocking the cars' intoxicating acceleration. The new BMW M6 Coupe dashes from rest to 100 km/h (62 mph) in 4.2 seconds, while the new BMW M6 Convertible reaches the same speed just 0.1 seconds later. The top speed of both models is electronically limited to 250 km/h (155 mph). Specifying the optional M Driver's Package raises this barrier to 305 km/h (189 mph).

The advances in engine development enshrined in M TwinPower Turbo technology are also reflected in the two new models' significantly greater efficiency compared to their predecessors. The high operating effectiveness of the engine, the standard-fitted Auto Start-Stop function and other examples of Efficient Dynamics technology, such as Brake Energy Regeneration and the volume-controlled oil pump, help to reduce fuel consumption and emissions by around 30 per cent. The new BMW M6 Coupe cards average fuel consumption of 9.9 litres per 100 kilometres (28.5 mpg imp) in the EU test cycle and CO₂ emissions of 232 grams per kilometre. The corresponding values for the new BMW M6 Convertible are 10.3 litres per 100 kilometres (27.4 mpg imp) and 239 grams per kilometre.

Harnessing the high output to dynamic effect: the seven-speed M Double Clutch Transmission with Drivelogic.

Tuned seamlessly to the performance characteristics of the V8 engine, the M Double Clutch Transmission with Drivelogic converts the powerplant's impressive thrust extremely effectively into rapid acceleration. This capability is underpinned by the DCT design principle, which effectively combines two gearboxes in one housing – yet with virtually no size or weight penalty over a conventional manual transmission. Inside the transmission, the torque is transferred via two oil-cooled wet clutches, which are engaged alternately. This allows zero interruption in the flow of power when the driver accelerates, even during gear changes.

M DCT Drivelogic offers the driver three different shift programs, both in automated mode (D) and manual mode (S). These programs alter the transmission's shift characteristics in terms of efficiency, shift comfort and sportiness and can be activated using the rocker switch located behind the selector lever on the centre console. Added to which, the electronics also provide a Launch Control function ensuring unbeatable acceleration from a standing start, Low Speed Assistance for easier low-speed operation and the Auto Start-Stop function for increased efficiency.

The special M gear selector is used for selecting D and S modes and for engaging reverse gear. In S mode the driver changes gears manually in a sequential format. The new BMW M6 Coupe and Convertible are also equipped as standard with a newly developed M leather steering wheel, complete with multifunction buttons and fixed gearshift paddles. In typical M configuration, the driver pulls the right-hand paddle to shift up and the left-hand paddle to shift down. The model-specific steering wheel stands out with its smaller rim diameter and a design which borrows from the double-spoke construction of the M light-alloy wheels.

Active M Differential delivers outstanding traction in dynamic driving situations.

The new BMW M6 Coupe and Convertible also impress by offering optimum traction in tricky road and weather conditions and under dynamic acceleration out of corners. Working behind the scenes to this end is an innovative variable locking differential in the rear differential. The Active M Differential allows the

engine's power to be split precisely and quickly between the left and right rear wheel according to the requirements of the driving situation at any particular moment.

An electronically controlled multi-plate limited-slip differential helps to reduce the rotational speed differences between the rear wheels, which is needed to optimise traction. The Active M Differential control unit is linked up to the DSC stability control system, allowing every driving situation to be precisely analysed and a loss of traction at one wheel to be detected at an early stage. The locking effect generated in response can be varied between 0 and 100 per cent, enabling wheel spin to be prevented on slippery surfaces, in instances where the left and right rear wheel have widely differing friction coefficients, in tight bends and when changing direction extremely dynamically. Optimising traction in this way also provides unbeatable driving stability in challenging conditions and allows impressively dynamic acceleration out of corners.

M-specific chassis technology, Dynamic Damper Control, M Servotronic, DSC with M Dynamic Mode.

The chassis of the new BMW M6 Coupe and Convertible has been developed to M specification and therefore combines outstanding performance attributes with the comfort-enhancing features drivers appreciate on an everyday basis. Like the integral rear axle, whose subframes are bolted rigidly to the body, the double-wishbone front axle boasts specific kinematics and newly developed components made from forged aluminium. Chassis mountings using large panels at the front and rear axle ensure dynamic forces are passed evenly through to the body. Through enthusiastically driven corners, this helps to noticeably reduce the roll movements triggered by bumps in the road surface. Both the construction of the chassis and its bespoke tuning for each model are defined by extensive expertise from the race track and have been optimised during extensive testing on the Nürburgring's Nordschleife circuit.

The standard equipment of both models also includes electronically controlled dampers. The M-specific Dynamic Damper Control system adjusts damping force electrohydraulically to provide the required responses for the driving situation at hand and fulfil the wishes of the driver. A choice of three

settings allows drivers to adjust the damper characteristics to their needs and preferences.

The hydraulic rack-and-pinion steering ensures unbeatable precision and a high degree of comfort. This system has a variable ratio, which enhances straightline stability and reduces the number of steering wheel turns required when parking and turning off a road. The likewise standard Servotronic speed-sensitive power assistance is specially tuned to M specification and allows drivers to choose a personal configuration with the help of three set-up options.

In addition to applying brake impulses and reducing engine output to stabilise the car, the DSC stability control system of the two high-performance sports cars also employs the services of the Anti-lock Braking System (ABS), Cornering Brake Control (CBC), Dynamic Brake Control (DBC), Brake Assistant, the Brake Drying function and Start-Off Assistant. M Dynamic Mode (MDM) can be activated to override the basic setting by pressing the DSC button. By raising the intervention thresholds of DSC, this mode makes it easier to move off on snow or loose sand with slightly spinning driven wheels. MDM mode also paves the way for the familiar M self-steering response. "DSC Off" mode can likewise be activated at the touch of a button.

An innovation designed to deliver precise handling:

M carbon-ceramic brakes.

The latest version of the compound high-performance braking system helps give the new BMW M6 Coupe and Convertible outstanding stopping power. Its stand-out features include even lower weight, excellent feel and fade-free performance even under heavy loads. The diameter of the inner-vented and perforated brake disks is 400 millimetres at the front and 396 millimetres at the rear. The six-piston fixed-calliper brakes at the front axle – painted dark blue metallic and complete with the M logo – are radially bolted to the pivot bearing.

The M carbon-ceramic brakes available for the first time for the new BMW M6 Coupe and Convertible (in conjunction with 20-inch M light-alloy wheels) are without parallel worldwide and take the cars' stopping power to another new level. The brake discs measure 410 millimetres in diameter at the front axle and 396 millimetres at the rear. Made from a new type of

carbon-fibre compound ceramic, the discs boast even greater resistance to heat and combine this with significantly reduced rotating masses. The M carbon-ceramic brakes are 19.4 kg (42.8 lb) lighter than the standard-fitted items, yet the innovative material also displays exceptional resistance to wear, and the operating life of the discs is many times that of conventional equivalents. The optional M carbon-ceramic system also sees six-piston fixed-calliper brakes at the front teaming up with single-piston floating-calliper brakes at the rear. The callipers can be identified by their special gold-coloured paint finish.

Lightweight design across the board, flawless occupant protection.

An intelligent blend of materials also gives the body structure impressive strength coupled with extremely low weight, allowing it to enhance both occupant protection and handling agility. As with the use of CFRP for the roof of the new BMW M6 Coupe, the choice of materials for all other body components slots into the all-round lightweight design strategy. The doors and bonnet of the two high-performance sports cars are made from aluminium, the front side panels from thermoplastic. In addition, their boot lids and – in the case of the BMW M6 Convertible – also the roof cover are made from the glass-fibre composite material SMC (Sheet Moulding Compound). A weight-to-power ratio of 3.3 kg/hp (7.3 lb/hp) for the new BMW M6 Coupe and 3.5 kg/hp (7.7 lb/hp) for the new BMW M6 Convertible points to the significant advances that have also been made in this area over the predecessor models.

Robust load-path structures, large and precisely defined deformation zones and highly efficient restraint systems provide the basis for a high level of passive safety in both models. The safety equipment fitted as standard includes front and side airbags, side curtain head airbags for both rows of seats in the new BMW M6 Coupe, and front airbags and head-thorax side airbags integrated into the seat frames of the new BMW M6 Convertible. The soft-top model also benefits from roll-over bars made from high-strength aluminium. Positioned behind the rear head restraints, these protective bars extend automatically in fractions of a second should there be a danger of the car rolling over. Both models come with three-point inertial-reel seat belts on all seats, belt force limiters and belt tensioners for the front seats and ISOFIX child seat attachments in the rear.

Both the new BMW M6 Coupe and new BMW M6 Convertible are designed as four-seaters, and space in the rear compartment has increased substantially compared with the predecessor models. The load capacity of the new BMW M6 Coupe stands at 460 litres. The new BMW M6 Convertible, meanwhile, can carry 300 litres of luggage in the boot with the soft-top down and 350 litres with it closed. Both models can be ordered with the optional ski bag, which slides between the rear seats courtesy of the through-loading facility.

M-specific cockpit design: flawless car control, made-to-measure luxury.

Newly developed M sports seats offer the driver and front passenger optimum lateral support through quickly-taken corners, but also a high level of comfort over long distances. The lightweight seats with integrated belt system have an M-specific design headlined by extremely prominent cushion and backrest bolsters, head restraints integrated into the backrests, eye-catching stitching emphasising the segments of the seats, and an M logo embossed into the shoulder area. The M sports seats have electric height, fore/aft and backrest angle adjustment, and also come with pneumatically adjustable lumbar support, a memory function and a manually adjustable thigh support. The M sports seats are fitted with active head restraints to reduce the risk of injury in a rear-end impact.

The luxurious interior ambience of the two cars is characterised by classy materials and dynamically moulded surfaces, and the bespoke design of the cockpit and centre console – cleverly drawing on the exclusive, high-performance sports car driving experience – lends it an extra individual flair. The instrument cluster with black-panel technology features classical circular instruments in traditional BMW M style, with red needles and white illumination, as well as model-specific displays and the M logo in the rev counter. The standard-fitted control system iDrive includes an on-board monitor with an exclusive flatscreen design, while the optional Navigation system Professional brings with it a 10.2-inch version of the Control Display bordered by a high-quality, galvanised chrome frame.

Arranged around the gearshift lever on the centre console designed specially for the new BMW M6 Coupe and Convertible are the buttons allowing drivers

to select their preferred settings for all the adjustable powertrain and chassis functions. The DSC mode, performance characteristics of the engine, Dynamic Damper Control mapping, M Servotronic responses and M DCT Drivelogic shift program can all be adjusted independently at the touch of a button. This allows drivers to put together a detailed set-up configuration for their car and store it by holding down one of the two M Drive buttons on the multifunction steering wheel. The two standard-fitted M Drive buttons allow the driver of the new BMW M6 Coupe and Convertible to store a dynamic-led configuration under the “M1” button, for example, and a comfort-biased set-up under “M2” – and to call up either in an instant and at any time. The settings stored on the M Drive buttons can also be configured using the iDrive menu.

As with the cars' performance characteristics, the aural profile of the engine can also be tweaked at the touch of a button. A sound module is used to enhance the engine's natural acoustic components and this soundtrack is then transported into the interior. The system's digital signal processing technology exchanges data directly with the engine management and adjusts its output to the engine's revs, the amount of torque being produced and the car's speed over the road. This gives the driver an impressively accurate impression of how hard the engine is currently working and of the power being unleashed, and provides an even clearer window into the car's responses on the road.

**High-quality standard equipment, exclusive options:
M-specific Head-Up Display, M multifunction seats,
Bang & Olufsen High-End Surround Sound System.**

The exclusive character of the two high-performance sports cars is underlined by the high-quality and extensive array of standard equipment they have on board – not to mention an unrivalled selection of high-tech options lending further depth to the driving experience. Standard equipment for both models includes 2-zone automatic climate control, heated seats for the driver and front passenger, fine-grain Merino leather trim with extended features, an M driver's footrest, exclusive carbon-fibre interior trim strips, door sill strips with “M6” lettering, plus ambient light in the interior, an automatically dimming rear-view mirror and exterior mirrors (the exterior mirrors also have a folding

function), Cruise Control with braking function, an alarm system and the BMW Professional radio with HiFi loudspeakers.

The range of optional driver assistance systems and mobility services available from BMW ConnectedDrive add unique touches to the two new models. The M-specific version of the Head-Up Display – which, alongside a digital speed readout and tips from the optional Speed Limit Info also shows the gear currently engaged and a multicolour rev counter symbol, complete with Shift Lights – is joined in the line-up by features including Park Distance Control, a rear-view camera, High Beam Assistant, Speed Limit Info, Lane Change Warning and Lane Departure Warning, Surround View and BMW Night Vision with pedestrian recognition. Added to which, innovative technologies optimise the integration of the Apple iPhone and other smartphones, as well as music players, and incorporate the use of internet-based services. The Apps option allows iPhone owners to receive web radio stations, for example, and display Facebook and Twitter posts on the on-board monitor. The Real-Time Traffic Information function, meanwhile, keeps the driver supplied with impressively accurate and detailed traffic bulletins.

Additional highlights of the options list include the Navigation system Professional with hard disk storage, M multifunction seats with electric backrest width adjustment, active seats, active seat ventilation, Comfort Access, a heated steering wheel, the Soft Close Automatic function for the doors, and the Bang & Olufsen High-End Surround Sound System. This audio system brings high performance into the world of in-car sound reproduction. The fully active system with digital signal processing comes with individual amplifiers for all the bass speakers, mid-range speakers and tweeters. Its centre speaker uses the Acoustic Lens Technology developed by Bang & Olufsen. As soon as the audio system is activated, the central element containing the integrated mid-range speaker pops up from the instrument panel, prompting the tweeter lens to extend out at the same time. The total of 12 loudspeakers in the new BMW M6 Convertible and 16 loudspeakers in the new BMW M6 Coupe deliver a uniquely rich and dynamic sound experience.

3. Specifications. BMW M6 Coupe.



		BMW M6 Coupe
Body		
No. of doors/seats		2 / 4
Length/width/height (unladen)	mm	4898 / 1899 / 1368
Wheelbase	mm	2851
Track, front/rear	mm	1630 / 1612
Ground clearance	mm	107
Turning circle	m	12.1
Tank capacity	approx. l	80
Cooling system incl heating	l	18,5
Engine oil ¹⁾	l	8.4
Weight, unladen, to DIN/EU	kg	1850 / 1925
Max load to DIN	kg	500
Max permissible weight	kg	2350
Max axle load, front/rear	kg	1180 / 1220
Max trailer load, braked (12%/unbraked)	kg	- / -
Max roof load/towbar download	kg	- / -
Luggage comp capacity	l	460
Air drag	$c_d \times A$	0.33 x 2.29
Engine		
Configuration/No of cyls/valves		V90 / 8 / 4
Engine technology		M TwinPower Turbo technology with cross-bank exhaust manifold, Twin Scroll Twin Turbo technology, High Precision Direct Petrol Injection, VALVETRONIC and Double-Vanos
Effective capacity	cm ³	4395
Bore/stroke	mm	88.3 / 89.0
Compression ratio	:1	10.0
Fuel grade		RON 98 (min 95)
Output	kW/hp	412 / 560
at	min ⁻¹	6000 – 7000
Torque	Nm	680
at	min ⁻¹	1500 – 5750
Electrical system		
Battery/Installation	Ah/-	105 / luggage comp
Alternator	A/W	210 / 2926
Driving dynamics and safety		
Suspension, front		Double track control arm with M-specific elastokinematics, small, negative steering roll radius, anti-dive
Suspension, rear		Integral-V multi-arm axle with M-specific elastokinematics, spatial suspension with anti-squat and anti-dive
Brakes, front		Six-piston fixed-calliper compound disc brakes
Diameter	mm	400 x 36 / vented
Brakes, rear		Single-piston floating-calliper compound disc brakes
Diameter	mm	396 x 24 / vented
Driving stability systems		Standard: DSC incl. ABS, ASC and MDM (M Dynamic Mode), CBC (Cornering Brake Control), DBC (Dynamic Brake Control), Dry Braking function, Start-Off Assistant, M Dynamic Damper Control, Active M Differential, linked to ICM (Integrated Chassis Management)
Safety equipment		Standard: airbags for driver and front passenger, side airbags for driver and front passenger, head airbags for front and rear seats, three-point inertia-reel seatbelts on all seats with belt latch tensioner and belt force limiter at the front, crash-activated head restraints at the front, crash sensors, Tyre Defect Indicator
Steering		Hydraulic rack-and-pinion steering with M-specific Servotronic function
Steering ratio, overall	:1	13.1
Tyres, front/rear		265/40 R19 102Y 295/35 R19 104Y
Rims, front/rear		9.5J x 19 LM 10.5J x 19 LM

BMW M6 Coupe

BMW ConnectedDrive

Convenience	Optional: BMW Assist incl. Enquiry Service, remote-control functions, Real-Time Traffic Information, BMW TeleServices, integration of mobile devices
Infotainment	Optional: internet access, BMW Online incl. Park Info, National Info, Google Local Search, News, Realtime Weather, BMW Routes, Office functions, Bluetooth Audio Streaming, Online Update Music Tracks, Apps
Safety	Optional: High Beam Assistant, Park Distance Control, rear-view camera, Surround View incl. Top View and Side View, BMW Night Vision with pedestrian recognition, Head-Up Display, Lane Change Warning, Lane Departure Warning, Speed Limit Info, Advanced eCall

Transmission

Type of gearbox	Seven-speed M Double Clutch Transmission with Drivelogic	
Gear ratios	I	4.806
	II :1	2.593
	III :1	1.701
	IV :1	1.277
	V :1	1.000
	VI :1	0.844
	VII :1	0.671
	R :1	4.172
Final drive	:1	3.154

Performance

Power-to-weight ratio	kg/kW	4.5
Output per litre	kW/l	93.7
Acceleration	0–100 km/h	s
	0–1000 m	s
		21.9
in 4 th /5th gear	80–120	s
		3.6 / 4.5
Top speed	km/h	250 / 305 ²⁾

BMW EfficientDynamics

BMW EfficientDynamics standard features	Brake Energy Regeneration with recuperation display, Auto Start-Stop function, intelligent lightweight construction, on-demand operation of ancillary units, flow rate-controlled power steering pump, tyres with reduced rolling resistance
---	--

Fuel consumption EU

Urban	l/100km	14.0
Extra-urban	l/100km	7.6
Combined	l/100km	9.9
CO ₂	g/km	232
Emission rating		EU5

Insurance group

3P / FCC / FC	³⁾
---------------	---------------

Specifications apply to ACEA markets; data relevant to homologation applicable in part only to Germany (weight)

- ¹⁾ Oil change quantity
- ²⁾ In conjunction with optional M Driver's Package
- ³⁾ Data not yet available

BMW M6 Convertible.

		BMW M6 Convertible
Body		
No. of doors/seats		2 / 4
Length/width/height (unladen)	mm	4898 / 1899 / 1368
Wheelbase	mm	2851
Track, front/rear	mm	1630 / 1612
Ground clearance	mm	107
Turning circle	m	12.1
Tank capacity	approx. l	80
Cooling system incl heating	l	18,5
Engine oil ¹⁾	l	8.4
Weight, unladen, to DIN/EU	kg	1980 / 2055
Max load to DIN	kg	430
Max permissible weight	kg	2410
Max axle load, front/rear	kg	1200 / 1260
Max trailer load, braked (12%/unbraked)	kg	- / -
Max roof load/towbar download	kg	- / -
Luggage comp capacity	l	300 – 350
Air drag	$c_d \times A$	0.33 x 2.29
Engine		
Configuration/No of cyls/valves		V90 / 8 / 4
Engine technology		M TwinPower Turbo technology with cross-bank exhaust manifold, Twin Scroll Twin Turbo technology, High Precision Direct Petrol Injection, VALVETRONIC and Double-Vanos
Effective capacity	cm ³	4395
Bore/stroke	mm	88.3 / 89.0
Compression ratio	:1	10.0
Fuel grade		RON 98 (min 95)
Output	kW/hp	412 / 560
at	min ⁻¹	6000 – 7000
Torque	Nm	680
at	min ⁻¹	1500 – 5750
Electrical system		
Battery/Installation	Ah/-	105 / luggage comp
Alternator	A/W	210 / 2926
Driving dynamics and safety		
Suspension, front		Double track control arm with M-specific elastokinematics, small, negative steering roll radius, anti-dive
Suspension, rear		Integral-V multi-arm axle with M-specific elastokinematics, spatial suspension with anti-squat and anti-dive
Brakes, front		Six-piston fixed-calliper compound disc brakes
Diameter	mm	400 x 36 / vented
Brakes, rear		Single-piston floating-calliper compound disc brakes
Diameter	mm	396 x 24 / vented
Driving stability systems		Standard: DSC incl. ABS, ASC and MDM (M Dynamic Mode), CBC (Cornering Brake Control), DBC (Dynamic Brake Control), Dry Braking function, Start-Off Assistant, M Dynamic Damper Control, Active M Differential, linked to ICM (Integrated Chassis Management)
Safety equipment		Standard: airbags for driver and front passenger, side airbags for driver and front passenger combined with head airbags, three-point inertia-reel seatbelts on all seats with belt latch tensioner and belt force limiter at the front, crash-activated head restraints at the front, roll-over protection system, crash sensors, Tyre Defect Indicator
Steering		Hydraulic rack-and-pinion steering with M-specific Servotronic function
Steering ratio, overall	:1	13.1
Tyres, front/rear		265/40 R19 102Y 295/35 R19 104Y
Rims, front/rear		9.5J x 19 LM 10.5J x 19 LM

BMW M6 Convertible

BMW ConnectedDrive

Convenience	Optional: BMW Assist incl. Enquiry Service, remote-control functions, Real-Time Traffic Information, BMW TeleServices, integration of mobile devices
Infotainment	Optional: internet access, BMW Online incl. Park Info, National Info, Google Local Search, News, Realtime Weather, BMW Routes, Office functions, Bluetooth Audio Streaming, Online Update Music Tracks, Apps
Safety	Optional: High Beam Assistant, Park Distance Control, rear-view camera, Surround View incl. Top View and Side View, BMW Night Vision with pedestrian recognition, Head-Up Display, Lane Change Warning, Lane Departure Warning, Speed Limit Info, Advanced eCall

Transmission

Type of gearbox	Seven-speed M Double Clutch Transmission with Drivelogic	
Gear ratios	I	4.806
	II	2.593
	III	1.701
	IV	1.277
	V	1.000
	VI	0.844
	VII	0.671
	R	4.172
Final drive		3.154

Performance

Power-to-weight ratio	kg/kW	4.8
Output per litre	kW/l	93.7
Acceleration	0–100 km/h	s
	0–1000 m	s
		22.1
in 4 th /5th gear	80–120	s
		3.8 / 4.8
Top speed	km/h	250 / 305 ²⁾

BMW EfficientDynamics

BMW EfficientDynamics standard features	Brake Energy Regeneration with recuperation display, Auto Start-Stop function, intelligent lightweight construction, on-demand operation of ancillary units, flow rate-controlled power steering pump, tyres with reduced rolling resistance
---	--

Fuel consumption EU

Urban	l/100km	14.4
Extra-urban	l/100km	7.9
Combined	l/100km	10.3
CO ₂	g/km	239
Emission rating		EU5

Insurance group

3P / FCC / FC	3)
---------------	----

Specifications apply to ACEA markets; data relevant to homologation applicable in part only to Germany (weight)

- ¹⁾ Oil change quantity
- ²⁾ In conjunction with optional M Driver's Package
- ³⁾ Data not yet available

4. Output and torque diagrams.

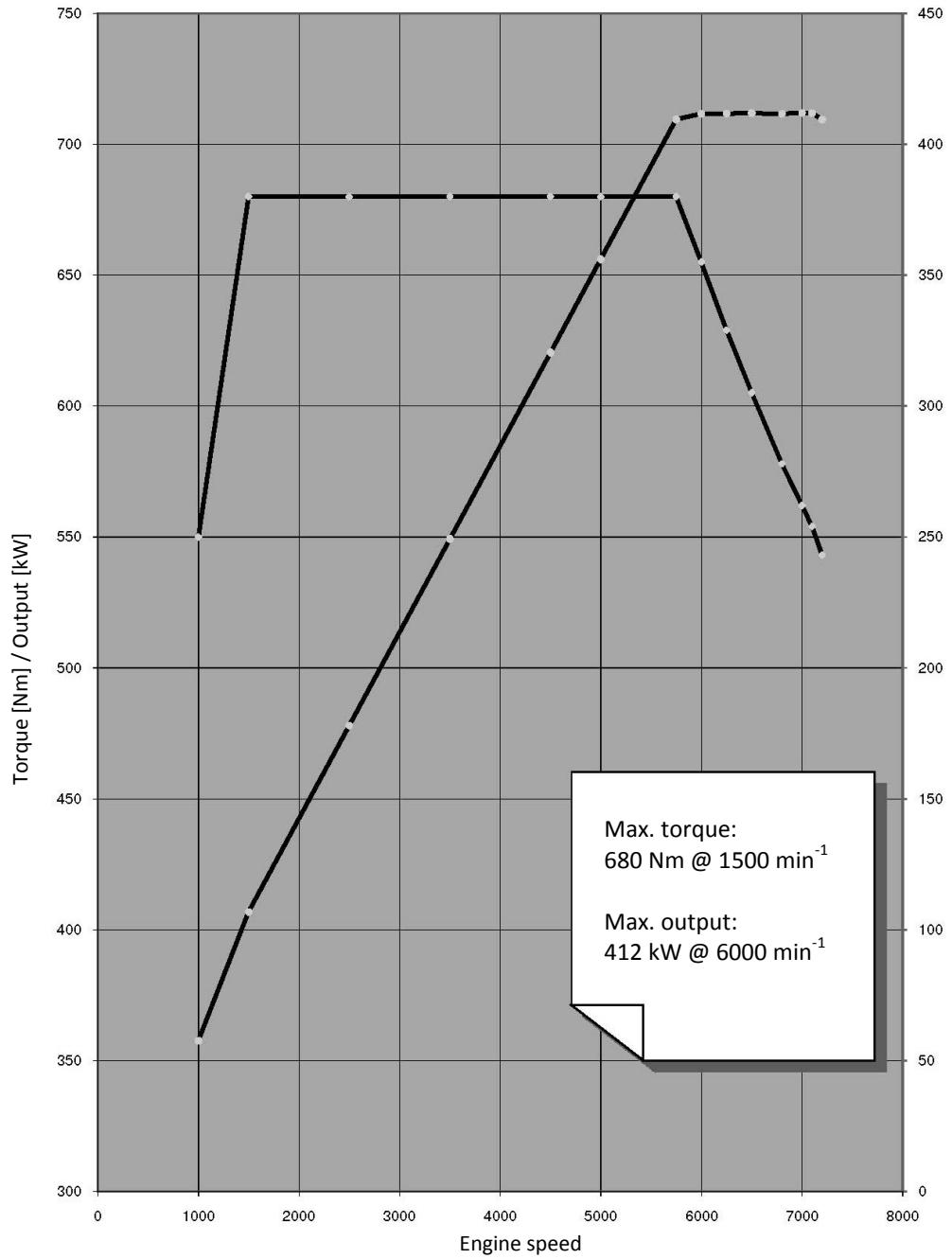

5. Exterior and interior dimensions. BMW M6 Coupe.

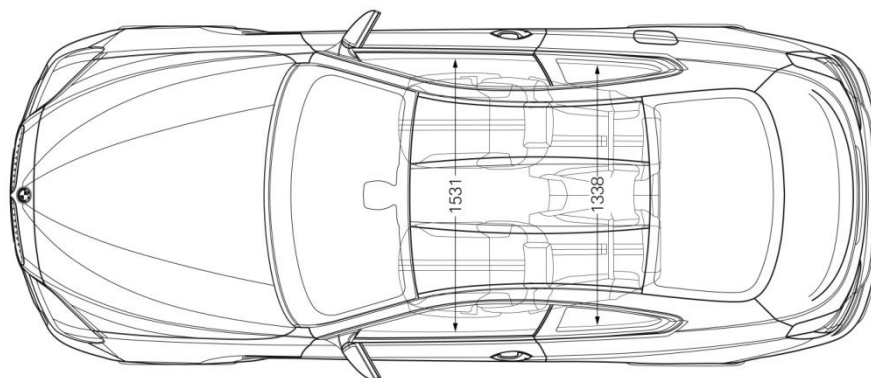
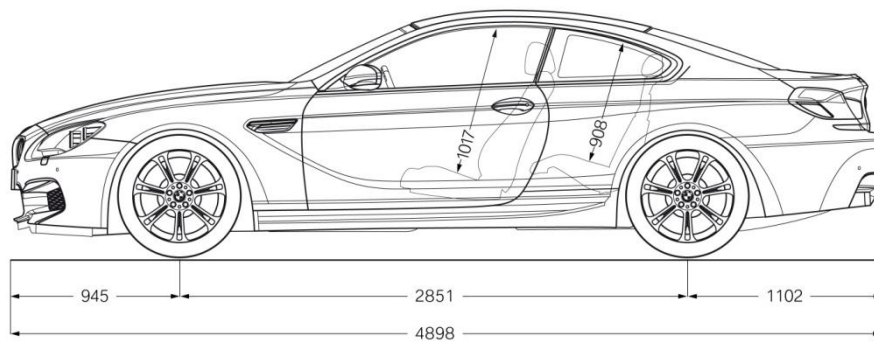
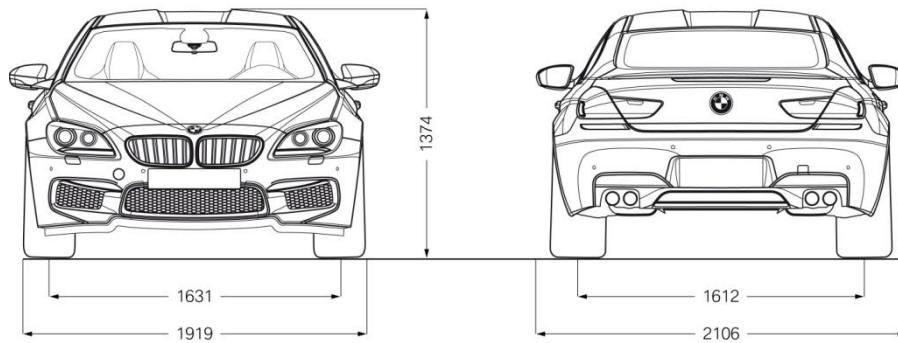

BMW M6 Convertible.

